

# POWERSELECT

## H-Series Compact Fluorescent Ballasts

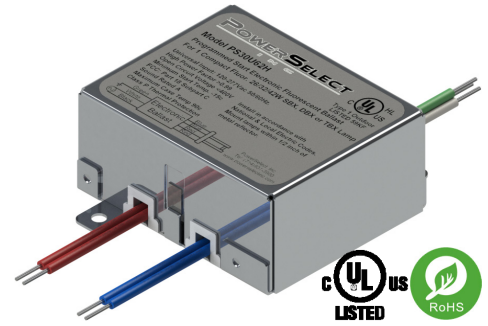

### Features

- Worldwide input voltage 90 through 305Vac, & 347Vac
- Output wattages from 13W through 42 Watt
- Hazardous Location Rated
- RoHS Compliant
- Pre-heat (programmed) Start
- Ignition Failure shutdown & End Of Lamp life protection
- 3-Year warranty

### Model Numbers & Specifications

Model	Input Voltage	Lamp Watage	Input Current	
PS30U18H	90-305Vac 50/60Hz.	13W-18W	13W = 0.13A @ 120V 18W = 0.16A @ 120V	13W = 0.05A @ 277V 18W = 0.07A @ 277V
PS30U62H	90-305Vac 50/60Hz.	26W-42W	26W = 0.22A @ 120V 42W = 0.38A @ 120V	26W = 0.10A @ 277V 42W = 0.17A @ 277V
PS30E18H	347Vac 50/60Hz.	13W-18W	13W = 0.05A @ 347V	18W = 0.7A @ 347V
PS30E62H	347Vac 50/60Hz.	26W-42W	26W = 0.08A @ 347V	42W = 0.13A @ 347V
<b>Power Factor</b>	>96%	<b>Lamp Drive Frequency</b>	52kHz Sinusoidal	
<b>THD</b>	<12%	<b>Crest Factor ANSI C82.11</b>	<1.4	
<b>Transient Immunity</b>	ANSI 62.41 CAT.A	<b>Mount Type</b>	Surface	

### Mechanical & Environmental

<b>Overall Enclosure Dimensions</b>	3.35" L x 2.95" W x 1.34" H
<b>Enclosure</b>	Anodized aluminum
<b>Input &amp; Output Wiring</b>	9" UL1015 # 18 AWG, rated 105°C
<b>Operating Temperature</b>	-30°C to 90°C
<b>EMI / RFI Compliance</b>	FCC Part 18
<b>Sound Rating</b>	Rated 'A'
<b>UL/CUL Listed Class 'P' File</b>	E201562

### Ballast Wiring

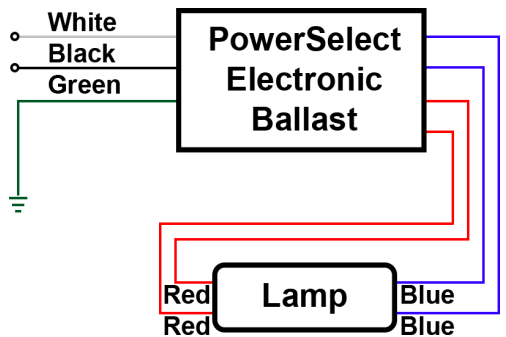

### Enclosure Dimensions

