

POWERSELECT

L-Series Compact Fluorescent Ballasts



Features

- Worldwide input voltage 90 *through* 305Vac
- Output wattages from 13W *through* 42 Watt
- Type HL—Hazardous Location Rated
- Pre-heat (programmed) Start
- Ignition Failure shutdown & End Of Lamp life protection
- 3-Year warranty

Model Numbers & Specifications

Model	Input Voltage	Lamp Watage	Input Current	
PS30U18L	90-305Vac 50/60Hz.	13W-18W	13W = 0.13A @ 120V	13W = 0.05A @ 277V
			18W = 0.15A @ 120V	18W = 0.07A @ 277V
PS30U62L	90-305Vac 50/60Hz.	26W-42W	26W = 0.22A @ 120V	26W = 0.10A @ 277V
			42W = 0.32A @ 120V	42W = 0.15A @ 277V
Power Factor	>96%	Lamp Drive Frequency	52kHz Sinusodial	
THD	<12%	Crest Factor ANSI C82.11	<1.4	
Transient Immunity	ANSI 62.41 CAT.A	Mount Type	Surface	

Mechanical & Environmental

Overall Enclosure Dimensions	5.57" L x 1.80" W x 1.02" H
Enclosure	Anodized aluminum
Input & Output Wiring	9" UL1015 # 18 AWG, rated 105°C
Operating Temperature	-30°C to 90°C
EMI / RFI Compliance	FCC Part 18
Sound Rating	Rated 'A'
UL/CUL Listed Class 'P' File	E201562

Ballast Wiring

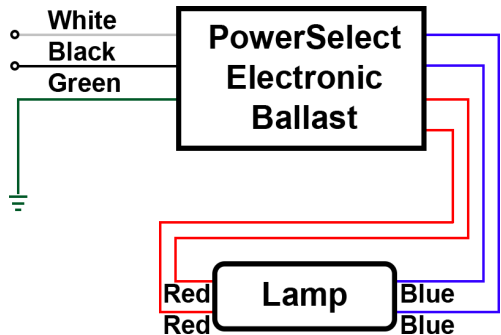

Enclosure Dimensions

